



## Share a Message of Peace on the Wings of a Crane

Peace Cranes have become symbolic of the need for world peace because Sadako Sasaki, a young girl from Hiroshima, began folding a thousand paper cranes and inspired children all over the world to fold cranes to promote peace.

This month, in honor of Martin Luther King, Jr. Day, generationOn challenges youth to contribute toward making 1,000 peace cranes to inspire others to be peacemakers.

### Materials:

- Origami paper (or magazine, newspaper, or notebook paper)
- Scissors
- Needle and thread (push the needle through the hole in the bottom of the crane and out through the point in the center of its back)
- Optional: spacers for stringing, such as straws or coffee stirrers cut into centimeter lengths

### Peace Pledge

#### Complete this pledge to display with the folded peace cranes:

In honor of the work of Martin Luther King, Jr.

I, \_\_\_\_\_ (name)

pledge to promote peace by

\_\_\_\_\_.

I care about \_\_\_\_\_

and want others to care about this too.

I know I can inspire others to be peacemakers.

### What can I do? Here are some ideas:

- Read the book *Sadako and the Thousand Paper Cranes* by Eleanor Coerr. (optional)
- Use the directions on the following pages to make folded paper cranes.
- Write a pledge of peace using the template above and display with your crane or write a message of peace on the wings of your crane.
- Decide with whom and how you will share your cranes and message. It may be an individual or group who needs your support, or post it in a public place to advocate for peace.
- Use Facebook to tell others to spread a message of peace. Ask your friends to like and share.
- Tweet or blog about your plans. Make it fun!
- Track your project and share your service story on [www.generationOn.org](http://www.generationOn.org).

# Folding a Paper Crane

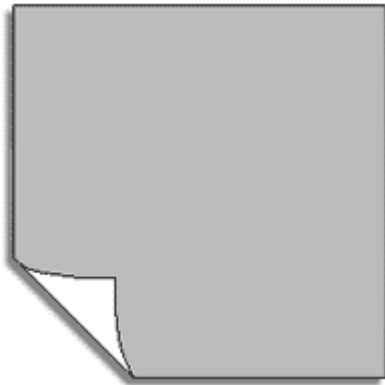

Begin with a square piece of paper -- ideally one side colored and the other plain. Place the colored side face up on the table. In all diagrams, the shaded part represents the colored side.

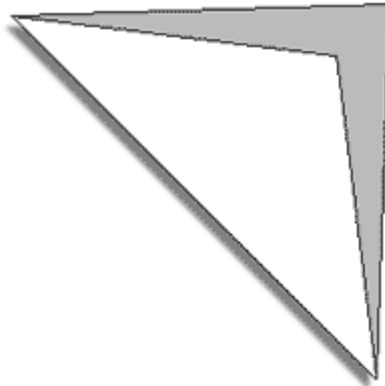

**1** Fold diagonally to form a triangle. Be sure the points line up. Make all creases very sharp. You can even use your thumbnail.

**Unfold** the paper. (Important!)

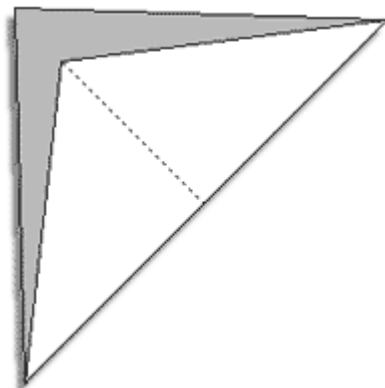

**2** Now fold the paper diagonally in the opposite direction, forming a new triangle.

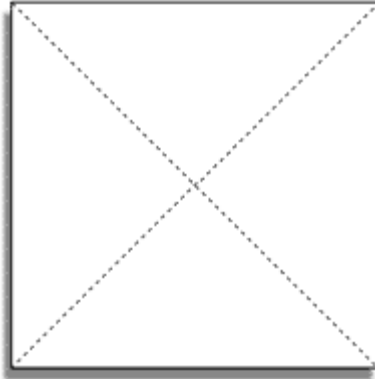

**Unfold** the paper and **turn it over** so the white side is up. The dotted lines in the diagram are creases you have already made.

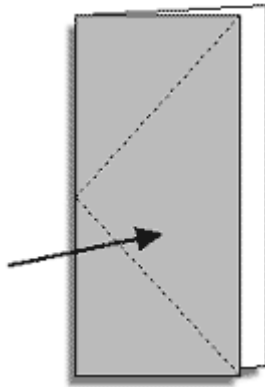

**3** Fold the paper in half to the "east" to form a rectangle.

Unfold the paper.

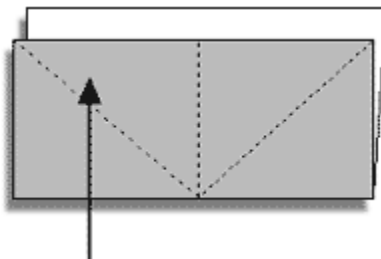

**4** Fold the paper in half to the "north" to form a new rectangle.

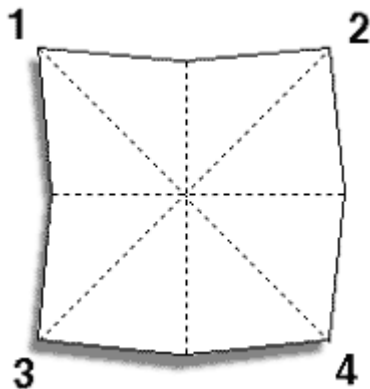

Unfold the rectangle, but don't flatten it out. Your paper will have the creases shown by the dotted lines in the figure on the right.

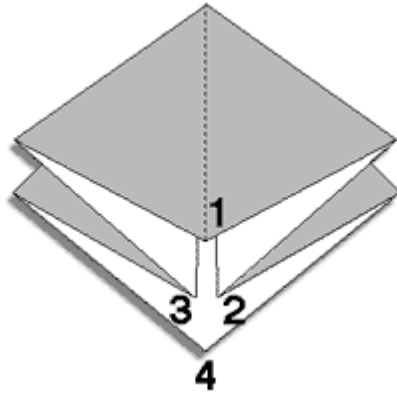

**5** Bring all four corners of the paper together, one at a time. This will fold the paper into the flat square shown on the right. This square has an open end where all four corners of the paper come together. It also has two flaps on the right and two flaps on the left.

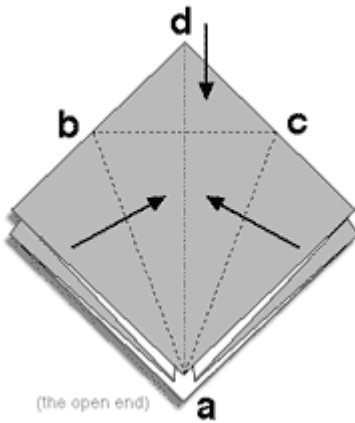

**6** Lift the **upper right** flap, and fold in the direction of the arrow. Crease along line a-c.

**7** Lift the **upper left** flap and fold in the direction of the arrow. Crease along the line a-b.

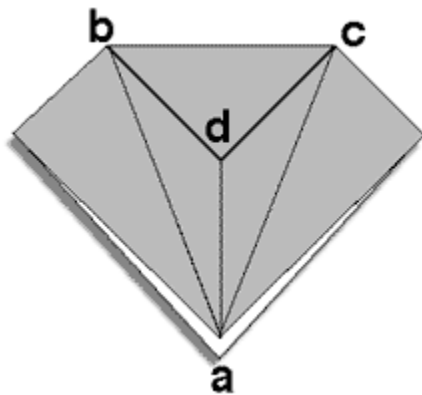

**8** Lift the paper at point d (see the previous diagram) and fold down the triangle bdc. Crease along the line b-c.

---

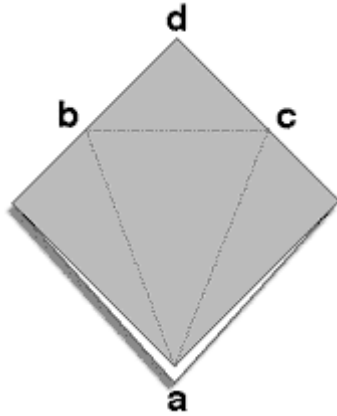

Undo the three folds you just made (steps 6, 7, and 8), and your paper will have the crease lines shown here (dotted lines).

**9** Lift just the top layer of the paper at point a. Think of this as opening a frog's mouth. Open it up and back to line b-c. Crease the line b-c inside frog's mouth.

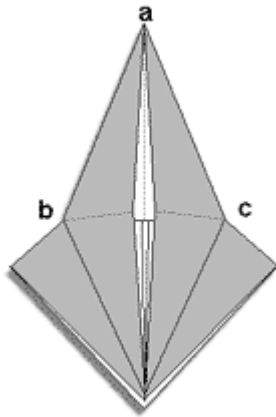

Press on points b and c to reverse the folds along lines a-b and a-c. The trick is to get the paper to lie flat in the long diamond shape shown here. At first it will seem impossible. Have patience.

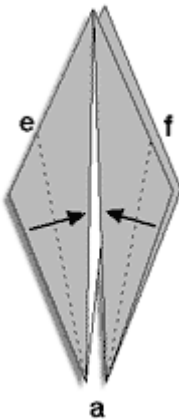

**10 - 13** Turn the paper over. Repeat Steps 6 to 9 on this side. When you have finished, your paper will look like this diamond with two "legs" at the bottom.

**14 & 15** Taper the diamond at its legs by folding the top layer of each side in the direction of the arrows along lines a-f and a-e so that they meet at the center line.

**16 & 17** Flip the paper over. Repeat steps 14 and 15 on this side to complete the tapering of the two legs.

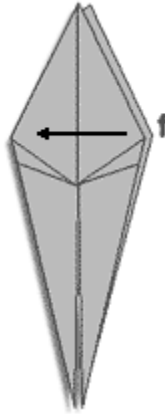

**18** This figure has two skinny legs. Lift the upper flap at point f (be sure it's just the upper flap), and fold it over in the direction of the arrow - as if turning the page of a book. This is called a "book fold".

Flip the entire figure over.

**19** Repeat this "book fold" (step 18) on this side. Be sure to fold over only the top "page".

---

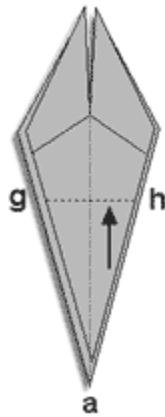

**20** This figure looks like a fox with two pointy ears at the top and a pointy nose at the bottom. Open the upper layer of the fox's mouth at point a, and crease it along line g-h so that fox's nose touches the top of the fox's ears.

**21** Turn the figure over. Repeat step 20 on this side so that all four points touch.

---

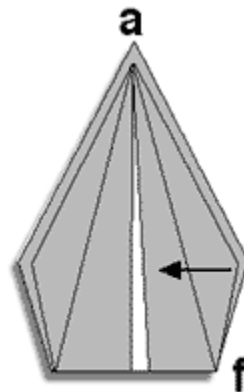

**22** Now for another "book fold". Lift the top layer (at point f), and fold it in the direction of the arrow.

**23** Flip the entire figure over. Repeat the "book fold" (step 22) on this side.

---

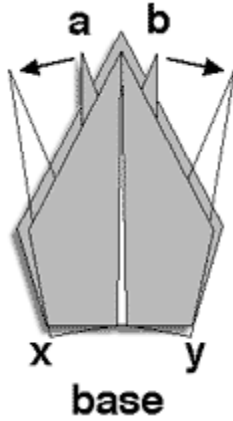

**24 & 25** There are two points, a and b, below the upper flap. Pull out each one, in the direction of the arrows, as far as shown. Press down along the base (at points x and y) to make them stay in place.

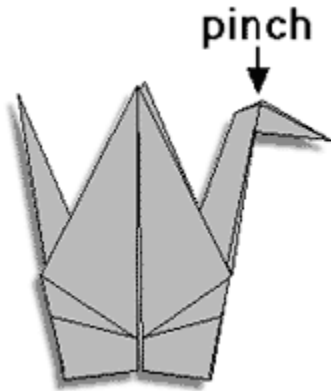

**26** Take the end of one of the points, and bend it down to make the head of the crane. Using your thumbnail, reverse the crease in the head, and pinch it to form the beak. The other point becomes the tail.

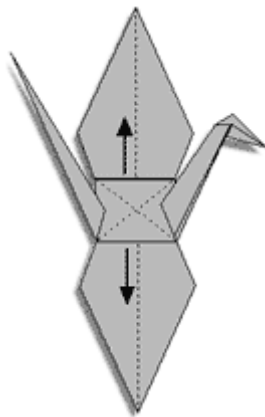

Open the body by blowing into the hole underneath the crane, and then gently pulling out the wings. And there it is!